



**DC INVERTER MINI VRF
OUTDOOR UNITS
81HM SERIES**

INSTRUCTION MANUAL

WARNING!

Read and follow all safety precautions in Instruction Manual - improper use can cause serious injury.

User Notice

During using, the total capacity of indoor units in simultaneous service shall not exceed the capacity of outdoor unit; Otherwise the cooling (or heating) output of each indoor unit will be low.

※ Install a circuit breaker (or fuse) to each indoor unit according to capacity of the unit and a master circuit breaker to all indoor units. Each of the circuit breaker, which are normally on, is used for short circuit and abnormal overload protection of indoor unit. The master circuit breaker is used to supply or cut off power of all indoor units together. The general power supply of all indoor units must be cut off before cleaning them.

※ For smooth start of air conditioner unit, the main power switch shall be put to "ON" position 8 hours before start.

※ Upon receiving of STOP signal by each indoor unit, the fan of related indoor unit will continue to work for 20~70 seconds for purpose of utilizing the remaining cold air or heats in heat exchanger and also make preparations for next use. This is normal.

※ When the run mode selected for indoor unit conflicts against the run mode of outdoor unit, the fault indicator on indoor unit will blink after 5 seconds or the operation of line controller display will conflict, while the indoor unit will be stopped. To resume the normal status in this case, you shall switch the run mode of indoor unit until it does not conflicts against the run mode of outdoor unit. The cooling mode does not conflict against the dehumidify mode, nor fan mode against other modes.

※ During installation, do not mix communication lines with power cables. Be sure to separate them at minimum spacing over 30cm; otherwise it might result in communication problem.

Make sure the heater band of the compressor work 8 hours continuously before the compressor was started up when the system is being debugged or maintained. The system has to work more than 30 minutes continuously once the compressor is started up, or damage to compressor may occur.

Contents

1. Safety Considerations	1
2. Selection of Installation Location and Precautions	2
2.1 Selection of Installation Location for Air Conditioner Unit	2
2.2 Cable Layout	3
2.3 Grounding Requirement	4
2.4 Noise Control	4
2.5 Accessories for Installation Use	4
3. Installation of Outdoor Unit	5
3.1 Precautions on Installation of Outdoor Unit	5
3.2 Outline Dimension of Outdoor Unit	5
3.3 Outdoor Unit Installation Space Dimension	6
3.4 Electrical Cable Connection	6
4. Connection of Indoor and Outdoor Unit	7
4.1 Manifolding Mode of Connecting Pipe	7
4.2 Y-type manifold pipe	7
4.3 Allowable Length and Drop Height of Connecting Pipe	8
4.4 Dimension of Connecting Pipe	9
4.5 Connection of Outlet Pipe for Indoor & Outdoor Unit	10
4.6 Connection of Manifold Pipe	10
4.7 Installation of Protective Layer on Connection Pipe	11
5. Connection of Communication Line for Indoor Unit and Outdoor Unit	12
6. Instructions for DIP Switch	13
6.1 set the addrss code and capacity code for indoor unit	13
7. Filling of Refrigerant and Test Run	14
7.1 Filling of Refrigerant	14
7.2 Calculating Mass of Additional Refrigerant	14
7.3 Inspection Items after Installation	16
7.4 Test-running	17
8. Operating Principle of Air-Conditioning Unit	18
8.1 Heat Pump Type Mini D.C.Inverter Multi-Connected Air-Conditioning Unit	18
8.2 Types of Indoor Units to Be Integrated	19
9. Maintenance Measures	20
9.1 Inspection at the Beginning of Operational Season	20

9.2 Maintenance at the End of the Operational Season	20
9.3 Maintenance Measures	21
10. Trouble shooting	22
10.1 If there is a error detected during operation:.....	22
10.2 Aftersales Service	24
11. Unit Working Condition	24
11.1 Rated working condition.....	24
11.2 The range of production working temperature	24

1. Safety Considerations

- 1). Please read this manual carefully before use and operate correctly as instructed in the manual.
- 2). You are specially warned to note the two symbols below.

 **WARNING!**: A symbol indicating that improper operation might cause human death or severe injuries.

 **CAUTIONS!**: A symbol indicating that improper operation might cause human injury or property damage.

WARNING!

※ This appliance is not intended for use by persons (including children) with reduced physical, sensory or mental capabilities, or lack of experience and knowledge, unless they have been given supervision or instruction concerning use of the appliance by a person responsible for their safety. Children should be supervised to ensure that they do not play with the appliance.

※ Please seek an authorized repair station for installation work. Improper installation might cause water leakage, electric shock or fire.

※ Please install at a place strong enough to support the weight of air conditioner unit. If not, the air conditioner unit might fall down and cause human injury or death.

※ To ensure proper drainage, the drainage pipe shall be correctly installed according to installation instructions. Take proper measures for heat preservation to prevent condensing. Improper installation of pipes might cause leakage and wet the articles in the room.

※ Do not use or store flammable, explosive, poisonous or other dangerous substances beside the air conditioner.

※ In case of trouble (e.g. burnt smell), please immediately cut off the main power of air conditioner unit.

※ Keep air flow to avoid shortage of oxygen in the room.

※ Never insert your finger or any objects into air outlet and inlet grill.

※ Please take constant care to check if the mounting rack is damaged after long use.

※ Never modify the air conditioner. Please contact the dealer or professional installation workers for repair or relocation of the air conditioner.

Cautions!

※ Before installation, please check the power supply for compliance with the ratings on nameplate. Check the power safety as well.

※ Before use, please check and confirm if the cables, drainage pipes and pipelines are correctly connected, hence to eliminate the risk of water leakage, refrigerant leakage, electric shock or fire.

※ Main power must be securely earthed to ensure effective grounding of air conditioner unit and avoid the risk of electric shock. Please do not connect the earthing cable to coal gas pipe, water pipe, lightning rod or telephone line.

※ Once started, the air conditioner shall not be stopped at least after 5 minutes or longer; otherwise service life the unit will be affected.

※ Do not let the child to operate the air conditioner unit.

- ※ Do not operate the air conditioner unit with wet hands.
- ※ Please disconnect the main power before cleaning the air conditioner or replacing the air filter.
- ※ Please disconnect the main power if to put the air conditioner unit out of use for a long period.
- ※ Please do not expose the air conditioner unit directly under corrosive environment with water or moisture.
- ※ Please do not foot on or place any goods on air conditioner unit.
- ※ After electrical installation, the air conditioner unit shall be energized for electrical leakage test.

2. Selection of Installation Location and Precautions

2.1 Selection of Installation Location for Air Conditioner Unit

The installation of air conditioner unit must be in accordance with national and local safety codes.

Installation quality will directly affect the normal use of air conditioner unit. The user is prohibited from installation by himself. Please contact your dealer after buying this machine. Professional installation workers will provide installation and test services according to installation manual.

Do not connect to power until all installation work is completed.

2.1.1 Selection of Installation Location for Indoor Unit

- ◆ Avoid direct sunshine.
- ◆ Ensure the hanger rod, ceiling and building structure have sufficient strength to support the weight of air conditioner unit.
- ◆ Drainage pipe is easy to connect out.
- ◆ Air flow at inlet and outlet air is not blocked.
- ◆ Indoor and outdoor connection pipes are easy to go outdoors.
- ◆ Do not install at a place where flammable or explosive goods exist or flammable or explosive gas might leak.
- ◆ Do not install at a place subject to corrosive gas, severe dust, salty fog, smoke or heavy moisture.

2.1.2 Select Installation Location of Outdoor Unit

- ◆ Outdoor unit must be installed on a firm and solid support.
- ◆ Outdoor unit shall be installed close to the indoor unit, hence to minimize the length and bends of cooling pipe.
- ◆ Avoid placing the outdoor unit under window or between two constructions, hence to prevent normal operating noise from entering the room.
- ◆ Air flow at inlet and outlet shall not be blocked.
- ◆ Install at a well-ventilated place, so that the machine can absorb and discharge sufficient air.
- ◆ Do not install at a place where flammable or explosive goods exist or a place subject to severe dust, salty fog and polluted air.

Do not install induced draught pipe at the let and outlet of the outdoor unit. When the air conditioner unit is generating heats indoors, the condensate water may flow from the base of outdoor unit. When outdoor air is below 0°C (32°F), the condensate water will be frozen. Take care that the installation of outdoor unit shall not affect the heat radiation of the unit.

⚠ Caution!

Installation at following positions might cause trouble to the air conditioner unit. If unavoidable, please contact DELTA Authorized Service Center.

- ① . A place full of machine oil;
- ② . A region with saline-sodic soil near the sea;
- ③ . A place with sulphide gases (such as sulphur spring);
- ④ . A place with high frequency facilities, such as radio equipment, electric welder or medical equipment;
- ⑤ . An environment with special conditions.

2.2 Cable Layout

- ◆ Carry out installation in accordance with the state line layout rules.
- ◆ The power supply must be of rated voltage of the unit and special electrical line for air-conditioning.
- ◆ Please do not pull the power supply line violently.
- ◆ All electrical installation shall be carried out by professional technicians in accordance with the local laws and regulations
- ◆ The diameter of flexible power cable must be large enough; damaged flexible power cable and connection cable must be replaced by flexible cables of such special purpose.

Ensure safe grounding and the grounding wire shall be connected with the special grounding equipment of the building and must be installed by professional technicians. In the fixed line there must be an electrical leakage protection switch and an air switch with sufficient capacity (refer to the following table). The air switch shall also have the magnetic tripping and thermal tripping functions to achieve protection of both short-circuit and overload.

An air switch having a contact separation of at least 3mm in all poles should be fixed in fixed wiring.

Model	power supply	Switch of capacity for air	Suggested conducting line(*area of section)
81HM003J24	208-230V~,60Hz	32	3×4.0
81HM004J24	208-230V~,60Hz	32	3×4.0
81HM004J24	208-230V~,60Hz	40	3×6.0
81HM005J24	208-230V~,60Hz	40	3×6.0

NOTE:

- ① . The specifications of the breaker and power cable listed in the table above are determined based on the maximum power (maximum amps) of the unit.
- ② . The specifications of the power cable listed in the table above are applied to the conduit-guarded multi-wire copper cable (like, YJV copper cable, consisting of PE insulated wires and a

PVC cable jacket) used at 40°C and resistible to 90°C(see GB/T 16895.15). If the working condition changes, they should be modified according to the related national standard.

③ . The specifications of the breaker listed in the table above are applied to the breaker with the working temperature at 40°C. If the working condition changes, they should be modified according to the related national standard.

2.3 Grounding Requirement

◆ As air-conditioning unit is of Class 1 electrical appliance, reliable grounding measures must be taken for it.

◆ The double color (yellow and green) cable inside the unit is specially used for grounding, so it shall not

◆ be used for other purposes nor can it be cut. Do not tighten with tapping screws; otherwise it might cause risk of electric shock.

◆ The ground resistance shall be in conformity with the requirements of state standard GB17790.

◆ The user power supply shall have reliable grounding terminal. It is prohibited to connect the grounding wire to the following items:

- ① . Water Supply Pipe;
- ② . Gas Pipe;
- ③ . Sewage Pipe;
- ④ . Other positions that are considered to be unreliable by professionals.

2.4 Noise Control

◆ Install the air conditioner unit at a well-ventilated place; otherwise it might result in decreased working capacity or higher noise.

◆ Install the air conditioner unit securely on a base that can fully support its weight; otherwise vibration and noise might be caused.

◆ Install the outdoor unit so that the hot air or noise will not disturb your neighbors.

◆ Do not place any obstacle close the outlet of outdoor unit; otherwise it might result in decreased working capacity or higher noise.

◆ If the air conditioner gives out abnormal noise during use, please immediately contact your dealer.

2.5 Accessories for Installation Use

For the accessories for installation of indoor units and outdoor unit, please see the Packing List in the package.

3. Installation of Outdoor Unit

3.1 Precautions on Installation of Outdoor Unit

To ensure the unit in proper function, selection of installation location must be in accordance with following principles:

- ◆ Outdoor unit shall be installed so that the air discharged by outdoor unit will not return and that sufficient space for repair shall be provided around the machine.
- ◆ Place of installation must be well ventilated so that the machine can absorb and discharge sufficient air. Ensure the air inlet and outlet of the machine are not blocked. If blocked, please clear off the obstacles blocking the air inlet or outlet.
- ◆ Place of installation shall be strong enough to support the weight of outdoor unit, and it shall be able to insulate noise and prevent vibration. Ensure that the wind and noise from the unit will not affect your neighbors.
- ◆ Outdoor unit must be lifted by using designated lifting hole. Take care to protect the unit during lift. To avoid rusting, do not knock the metal parts.
- ◆ Try best to avoid direct sunshine.
- ◆ Place of installation must be able to drain the rainwater and defrosting water.
- ◆ Place of installation must ensure the machine will not be buried under snow or subject to the influence of rubbish or oil fog.
- ◆ To meet the noise and vibration requirements, the outdoor unit shall be installed with rubber damper or spring damper.
- ◆ Installation dimension shall be in accordance with the installation requirements in this manual. Outdoor unit must be securely fixed to the position.
- ◆ The unit shall be installed by professional technicians.

3.2 Outline Dimension of Outdoor Unit

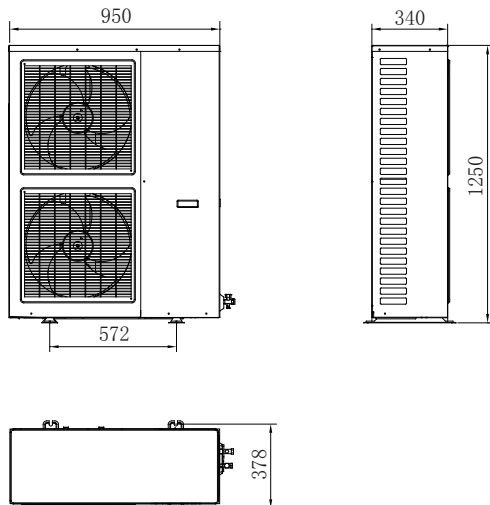

3.3 Outdoor Unit Installation Space Dimension

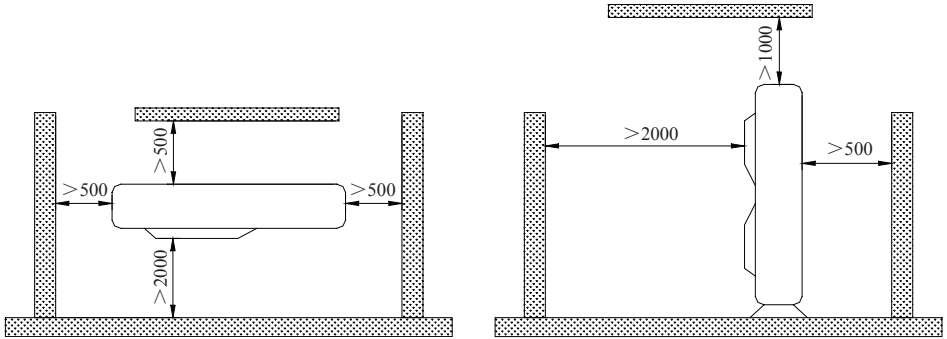

3.4 Electrical Cable Connection

⚠ Caution!

Outdoor unit and indoor unit may be of unified power supply or separate power supply. But the indoor units must be of unified power supply.

Be sure install a circuit breaker that can cut off the power of complete system.

3.4.1 Power Cable Connection:

- 1). Pass the cable through rubber ring.
- 2). 81HM003J24, 81HM004J24, 81HM004J24, 81HM005J24
to connect the power cable to the terminal marked "L & N" and earthing screws.
- 3). Fix the cables with cable clamp.

3.4.2 Connection of Distribution (Communication) Line:

- 1). Open the electric box on outdoor unit.
- 2). Pass the distribution (communication) line into top hole of the side board and through the rubber ring of electrical box.
- 3). Insert the distribution (communication) line into 3-pin terminal CN10 or CN20 on outdoor unit circuit board.
- 4). Fix the distribution (communication) lines properly.
- 5). Put back the junction cover plate and tighten the screws. Cover up the panel.

4. Connection of Indoor and Outdoor Unit

4.1 Manifolding Mode of Connecting Pipe

Connecting pipes for indoor unit and outdoor unit are in manifold mode. (As shown below).

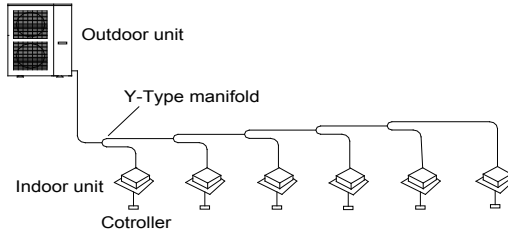

4.1.1 Indoor and Outdoor Unit Capacity Code

	Capacity Level	Capacity Code	Capacity Level	Capacity Code
Indoor Unit	Type 22	22	Type 56	56
	Type 25	25	Type 71	71
	Type 28	28	Type 80	80
	Type 36	36	Type 90	90
	Type 45	45	Type 112	112
	Type 50	50	Type 140	140
	Type 56	56		
Outdoor Unit	Type 100	100		
	Type 120	120		
	Type 140	140		
	Type 160	160		

- ◆ The No. of connectable indoor units should be at least 2.
- ◆ One outdoor unit can drive up to 16 indoor units in maximum.
- ◆ The sum of indoor unit capacity codes can be selected 50%-135% of outdoor unit capacity code number.

4.2 Y-type manifold pipe

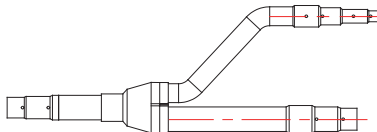

Y-type manifold pipe can be selected from following list:

	Total capacity of downstream indoor unit X	Model
Y-Type Manifold Pipe	$X \leq 200$	89BPK-0970
	$200 < X \leq 300$	89BPK-1102
	$300 < X \leq 700$	89BPK-2240

4.3 Allowable Length and Drop Height of Connecting Pipe

81HM003J24, 81HM004J24, 81HM004J24, 81HM005J24

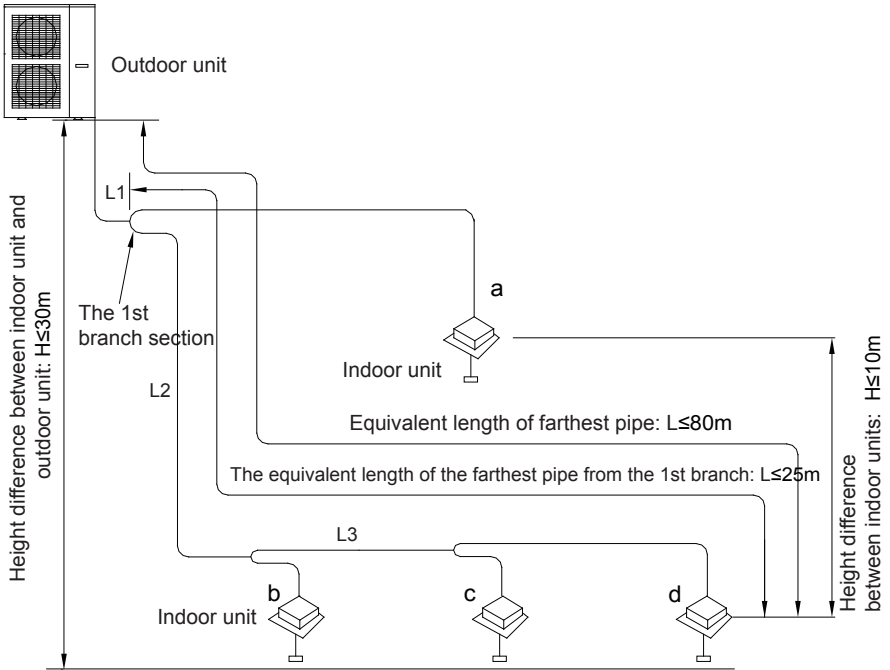

The equivalent length is designed based on every 0.5m for each Y-type branch pipe

		Allowable Value	Fitting Pipe
Total length (actual length) of fitting pipe		150m	$L1+L2+L3+a+b+c+d$
Length of farthest fitting pipe(m)	Actual length	70m	$L1+L2+L3+d$
	Equivalent length	80m	
Equivalent length from the 1st manifold pipe to farthest fitting pipe(m)		25m	$L2+L3+d$
Height difference between outdoor unit and indoor unit	Outdoor unit at upper	30m	—
	Outdoor unit at lower	25m	—
Height difference between indoor units(m)		10m	—

4.4 Dimension of Connecting Pipe

4.4.1 The fitting pipe (main pipe) from outdoor unit to the 1st manifold has the same dimension as the fitting pipe on outdoor unit.

Dimension of Indoor Unit Fitting Pipe

Item \ Model			81HM003J24	81HM004J24	81HM004J24	81HM005J24
			Connection Pipe	Liquid Pipe	mm	Φ9.52
Gas Pipe	mm	Φ15.9		Φ15.9	Φ15.9	Φ19.05
Connection type		Flare connection				

4.4.2 Dimension of the fitting pipes (manifold pipe) between manifolds is selected according to the capacity of the connected downstream indoor unit. The capacity of outdoor unit shall prevail if exceeded.

Unit: mm

Total Capacity of Indoor Units	Gas Pipe	Liquid Pipe
$C \leq 50$	Φ12.7	Φ6.35
$50 < C \leq 70$	Φ15.9	Φ9.52
$100 < C \leq 180$	Φ19.05	Φ9.52

4.4.3 The fitting pipe (indoor fitting pipe) from manifold to indoor unit has the same dimension as the indoor unit fitting pipe.

Dimension of Indoor Unit Fitting Pipe

Unit: mm

Capacity of Indoor Unit	Gas Pipe	Liquid Pipe
Model 22,25,28	Φ9.52	Φ6.35
Model 32,36,40,45,50	Φ12.7	Φ6.35
Model 36,45,50	Φ12.7	Φ9.52
Model 56,63,71,80,90,112,125,140	Φ15.9	Φ9.52

Note: When the capacity of indoor unit less than 5kW, if the distance from the nearest manifold to the indoor unit exceeds 10m, the fitting pipe on liquid side of the pipe shall be increased of one dimension.

4.5 Connection of Outlet Pipe for Indoor & Outdoor Unit

- ◆ See below for the torque required to tighten the nuts.
- ◆ Align the expansion end of copper pipe with the center of threaded joint. Tighten the flaring nuts with your hands.
- ◆ Tighten the flaring nuts with torque wrench until you hear a “click”.
- ◆ Bend of fitting pipe shall not be too low; otherwise the fitting pipe might crack. Please use pipe bender when bending the fitting pipe.
- ◆ Use sponge to wrap the connecting pipe and joints without heat preservation. Tie with plastic tapes.

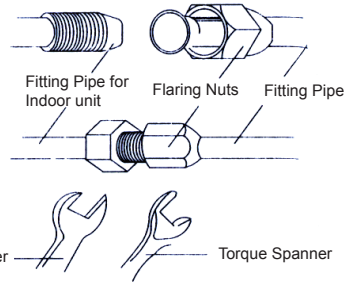

Torque Sheet for Tightening Nuts

Pipe Diameter(mm)	Wall Thickness(mm)	Tightening Torque (N·m)
Φ6.35	≥0.5	15-30
Φ9.52	≥0.7	30-40
Φ12.7	≥1	45-50
Φ15.9	≥1	60-65
Φ19.05	≥1	70-75

⚠ Caution!

- ① . When connecting indoor unit and pipe, never pull the big and small joint of indoor unit with force, so as to prevent the capillary tube or other tubes of indoor unit from cracking and causing leakage.
- ② . Connecting pipe shall be supported by a rack without transmitting its weight to other units.

4.6 Connection of Manifold Pipe

Y-Type Manifold Pipe

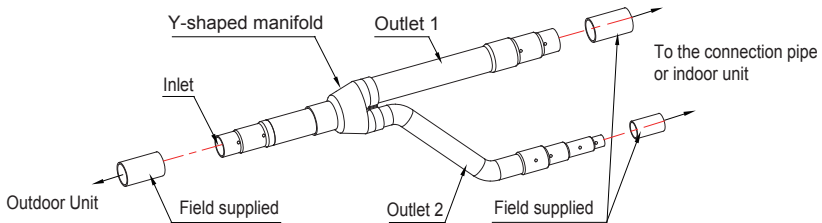

Y-type manifold pipe is equipped with auxiliary tubes to adjust the diameter of different pipes. If the dimension of the pipe selected for site use is different from the dimension of manifold pipe joint, use the pipe cutter to cut from the middle of the pipe with different dimensions, and deburr as well. Please see below.

Y-type manifold pipe must be installed so that the manifold is in vertical or horizontal direction.

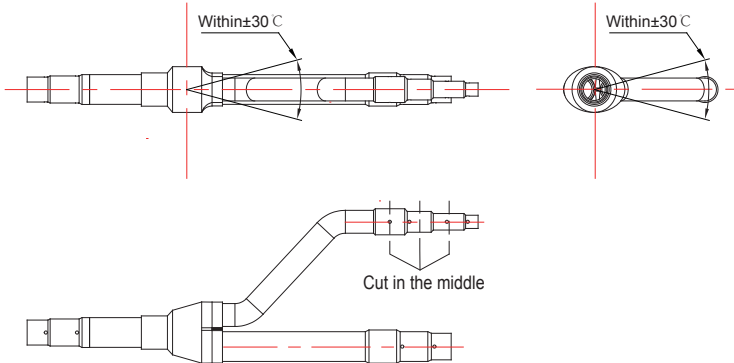

On air pipe side, heat preservation materials able to endure 120°C or a high temperature shall be used for heat preservation of manifold pipe. Do not use the foam on manifold pipe as the material for heat preservation. To prevent liquid pipe from leaking, it is required to connect the two types of heat

preservation materials end to end, i.e. the foam material on manifold pipe and the heat preservation

material used on site. After that, wrap up the joints between the two types of materials.

⚠ Caution!

For multi-split air conditioner system, each pipe shall be pasted with label to identify the pipe for each system and avoid wrong connection.

4.7 Installation of Protective Layer on Connection Pipe

- 1). To avoid condensate dew or water leakage on connecting pipe, the air pipe and liquid pipe must be wrapped with heat preservation material and adhesive pipe for insulation from the air.
- 2). The joints on indoor unit and outdoor unit must be wrapped with heat preservation materials and have no clearance against the wall surface of indoor unit and outdoor unit.

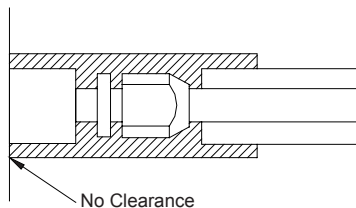

⚠ Caution!

When the pipe is properly protected, do not bend it to a very small angle; otherwise the pipe might crack or broken.

- 3). Wrap the pipe with tapes.
 - (1). Use the adhesive tape to wrap the connecting pipe and cable into one bundle. To prevent condensate water from overflowing out of the drainpipe, the drainpipe shall be separated from connecting pipe and cable.
 - (2). Wrap the heat preservation tape so that each ring of tape shall press half of the previous ring.
 - (3). Fix the wrapped pipe onto the wall with pipe clamp.

⚠ Caution!

- ① . Do not wrap the protective tape too tightly, as this will decrease the heat insulation performance. Ensure that the drain hose of condensate water is separated.
- ② . After completing the protection work and wrapping the pipe properly, close the wall holes with sealing materials.

5. Connection of Communication Line for Indoor Unit and Outdoor Unit

Open the electrical box of indoor unit and outdoor unit. Insert the distribution line (communication line) into electrical box via cable hole. Be sure to connect the indoor unit and outdoor unit in accordance with the wiring diagram labeled on the unit. (Refer to the electrical wiring of indoor unit and outdoor unit). The specification of power cable shall be selected in reference to the power capacity and installation environment of the unit. If no error, press wire clip respectively onto the cables tightly and then reinstall the electrical box cover. Magnetic rings shall be installed on two ends of the communication line.

Connect communication wire of indoor and outdoor unit by the following

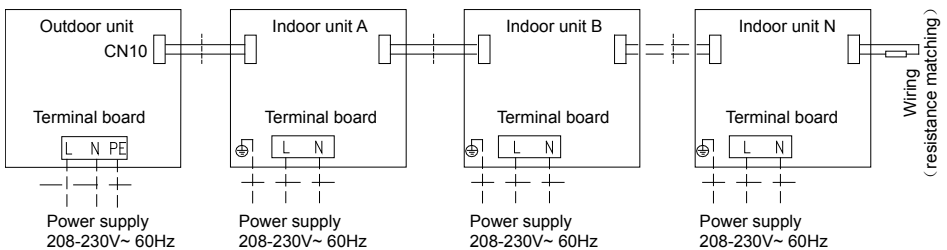

6. Instructions for DIP Switch

6.1 set the address code and capacity code for indoor unit

Set the address of the indoor unit according to the layout of the AC system , the address can't repeat in a same system.

8 bit DIP is adopted on the main board of the indoor unit to assign the indoor's address and capacity . The 5~8 bit that is used to assign the indoor's capacity has been set before shipment.It's only to adapt the 1~4 bit to set the indoor's address before installation.

4 bit DIP is adopted to the main board of wired controller to assign the address . The wired controller's address must be same with its corresponding indoor unit.

The mainboard of the wire controller has a 4-bit DIP controller to allocate the address of the controller. The address of the wire controller must be identical with the address of the corresponding indoor unit.

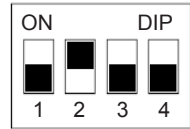

Address Setting of Indoor Unit and Wire Controller Are Shown in the Following Table:

Bits 1~4 for Address Setting									
Corresponding Pins of the 8-Bit (4-Bit) DIP Switch									
4	3	2	1	Allocated Address	4	3	2	1	Allocated Address
0	0	0	0	1	1	0	0	0	9
0	0	0	1	2	1	0	0	1	10
0	0	1	0	3	1	0	1	0	11
0	0	1	1	4	1	0	1	1	12
0	1	0	0	5	1	1	0	0	13
0	1	0	1	6	1	1	0	1	14
0	1	1	0	7	1	1	1	0	15
0	1	1	1	8	1	1	1	1	16

Note: The position "ON" means "0".

7. Filling of Refrigerant and Test Run

7.1 Filling of Refrigerant

- 1). Before shipped out from manufacturer, the outdoor unit has been filled with refrigerant. Additional refrigerant may be filled when carrying out site connection of pipelines.
- 2). Check the liquid valve and the gas valve of the outdoor unit. The valves shall be completely shut off.
- 3). Connect a vacuum pump to the liquid valve and the gas valve of the outdoor unit to remove air from the inside of the indoor unit and the connecting pipe. Refer to the following figure:

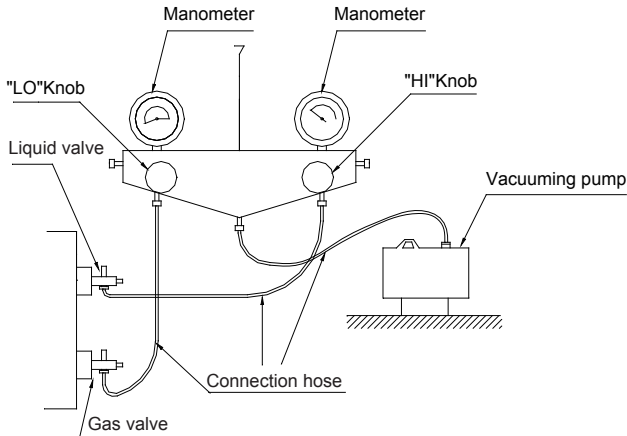

- 4). After confirming that there is no leakage from the system, when the compressor is not in operation charge additional R410A working fluid with specified amount to the unit through the filling opening of the liquid pipe valve of the outdoor unit.

7.2 Calculating Mass of Additional Refrigerant

7.2.1 Mass of Refrigerant in the System When Delivered from Manufacturer

Note:

The mass of refrigerant in the system when delivered from manufacturer does not include the mass of additional refrigerant needed by the piping connecting the outdoor unit and the indoor unit.

Model	81HM003J24	81HM004J24	81HM004J24	81HM005J24
Refrigerant charge (kg)	7.0	7.0	7.0	7.0

As the length of the connecting pipe is decided on site, the amount of additional refrigerant shall be decided depending on the size and the length of the liquid pipe used on site.

7.2.2 Method of Calculating Mass of Additional Refrigerant to Be Filled (Based on the Liquid Pipe)

Mass of Additional Refrigerant to Be Filled = \sum Length of Liquid Pipe \times Amount of Additional Refrigerant to Be Filled Per Meter of Liquid Pipe

Φ22.2	Φ19.05	Φ15.9	Φ12.7	Φ9.52	Φ6.35
0.35	0.25	0.17	0.11	0.054	0.022

7.2.3 Example for calculation

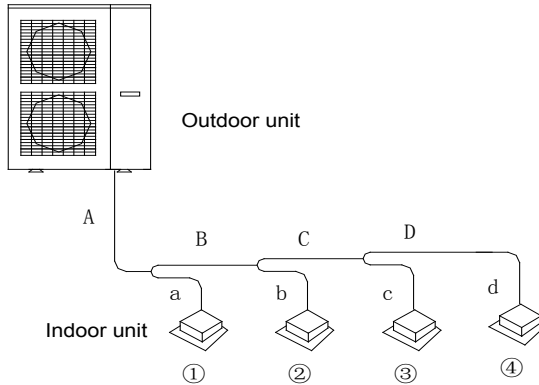

Indoor unit:

SN	Model
Indoor unit	Cassette type
Indoor unit	Wall Mounted type
Indoor unit	Single Side Air Supply type
Indoor unit	Ducted type

Liquid Pipe:

SN	A	B	C	D
Diameter of the pipe	Φ9.52	Φ9.52	Φ9.52	Φ6.35
Length	30m	10m	5m	5m
SN	a	b	c	d
Diameter of the pipe	Φ9.52	Φ6.35	Φ6.35	Φ6.35
Length	10m	10m	10m	10m

Total length of liquid pipes:

Φ9.52: $A+B+C+a=30+10+5+10=55\text{m}$

Φ6.35: $D+b+c+d=5+10+10+10=35\text{m}$

Notes: if total length is less than 50 meters, there is no need to add extra refrigerant.

So, the minimum required refrigerant amount should be $= (55-50) \times 0.054 + 35 \times 0.022 = 1.04\text{kg}$.

7.2.4 Record table for refrigerant charge

Indoor units:

SN	Indoor model number	Extra Refr. amount (Kg)
1		
2		
.....		
N		
Total amount		

Liquid pipe:

Liquid pipe diameter	Total length(mm)	Extra Refr. amount (Kg)
Φ15.9		
Φ12.7		
Φ9.52		
Φ6.35		
Total amount		

7.3 Inspection Items after Installation

Inspection items	Problems Owing to Improper Installation	Check
Is the installation reliable?	The unit may drop, vibrate or make noises	
Has the gas leakage been checked?	May cause unsatisfactory cooling (heating) effect	
Is the thermal insulation of the unit sufficient?	May cause condensation and water dropping	
Is the drainage smooth?	May cause condensation and water dropping	
Does the power supply voltage accord with the rated voltage specified on the nameplate?	The unit may bread down or the components may be burned out	
Are the lines and pipelines correctly installed?	The unit may bread down or the components may be burned out	
Has the unit been safely grounded?	Risk of electrical leakage	
Are the models of lines in conformity with requirements?	The unit may bread down or the components may be burned out	
Are there any obstacles near the air inlet and outlet of the indoor and outdoor units?	May cause unsatisfactory cooling (heating) effect	
Have the length of refrigerating pipe and refrigerant charge amount been recorded?	It is not easy to decide the charge amount of refrigerant.	

7.4 Test-running

7.4.1 Inspection item before Test-running

◆ Inspect that whether the appearance and pipe system are damaged when the unit was transported or convied.

◆ Inspect that whether the electronic components in the units are installed firmly and correctly

◆ Inspect that whether the fan rotates in right direction.

◆ Inspect that whether the valves are all opened

7.4.2 steps for running test

◆ Besides the above points ,test-running must be operated by professional.

◆ Power the units , then turn on the wired controller and remote controller.

◆ The indoor fan and compressor will start-up automatically in one minutes .

◆ Turn off and inspect the compressor immediately if there is any abnormal noise after the compressor was start-up

8. Operating Principle of Air-Conditioning Unit

8.1 Heat Pump Type Mini D.C.Inverter Multi-Connected Air-Conditioning Unit

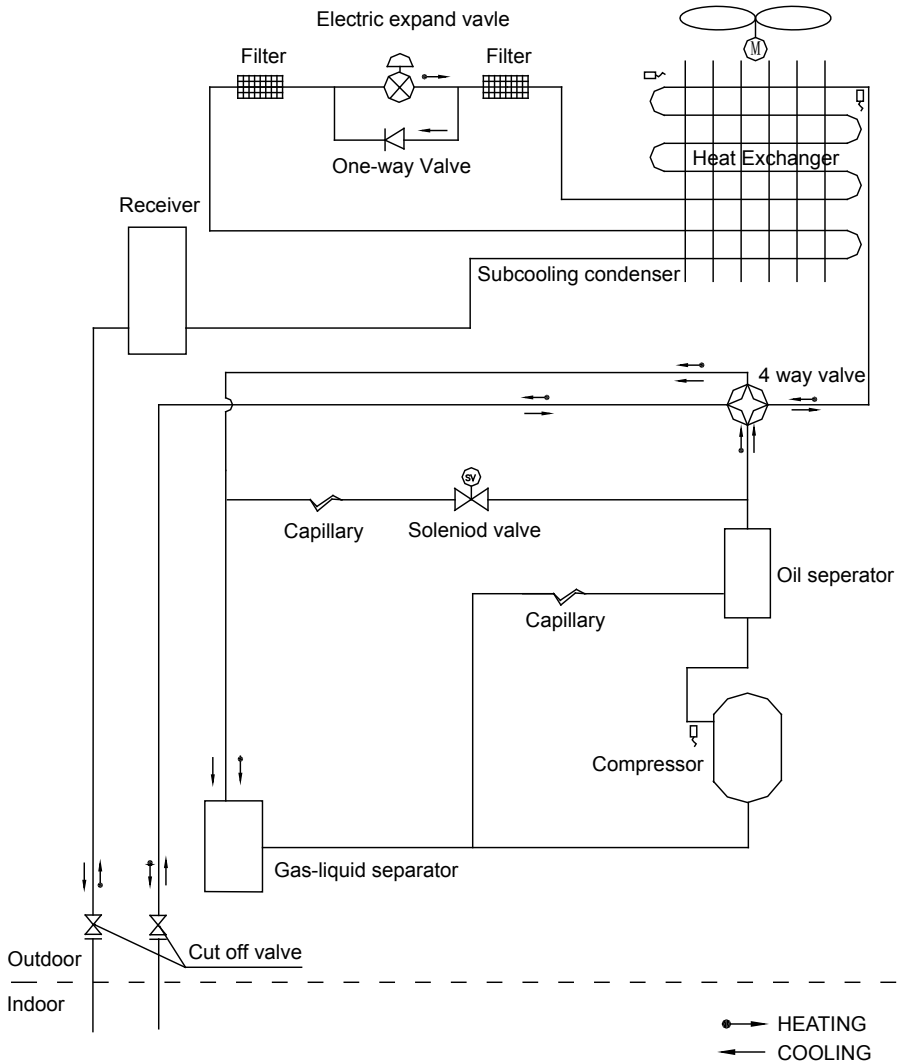

Operating Principle Diagram of Heat Pump Type Mini D.C.Inverter Multi Variable Air-Conditioning Unit

Connect the system to power supply, and the indoor units and the outdoor unit shall start to operate. When the system is in cooling operation, the low-temperature and low-pressure refrigerant gas from the heat exchangers of the indoor units converge and is absorbed by the compressor to be compressed into high-temperature and high-pressure gas. After that, the gas is discharged into the heat exchanger of the outdoor unit for heat exchange with the air at the outdoor side, so the

gas is changed into refrigerant liquid. The liquid flows into all the indoor units through the Y-type manifold and then passes the throttling component for decrease of pressure and temperature. The liquid then enters the heat exchanger of the indoor unit and carries out heat exchange with the room air to be regulated. The liquid then changes into low-temperature and low-pressure gas. Such cycle repeats again and again to achieve the purpose of cooling. When the system turns to heating operation, the 4-way reversing valve with solenoid coil shall be started to cause the heating cycle follows an adverse course compared with the course of the cooling cycle. The refrigerant radiates heat in the heat exchanger of the indoor unit (the electric heating component also starts operation and radiates heat) and absorbs heat from the heat exchanger of the outdoor unit to carry out heat pump heating cycle for the purpose of heating.

8.2 Types of Indoor Units to Be Integrated

Diagram of System Integration

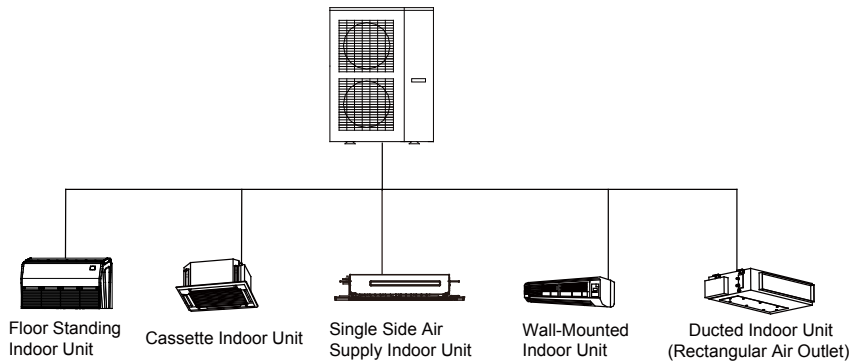

Mini D.C. Inverter multi-connected air-conditioning unit consists of one outdoor unit and up to 16 indoor units. The indoor unit can be of cassette type, single side air supply type, wall-mounted type, ducted type, and floor standing type, etc. The wall-mounted type and the floor standing type indoor units are controlled by remote controller; the ducted indoor unit is controlled by remote controller and wire controller. For the cassette indoor unit and single side air supply cassette indoor unit, remote controller or wire controller can be freely chosen. When any indoor unit receives an operation order, the outdoor unit shall start operation; when all indoor units stop operation, the outdoor unit shall stop.

9. Maintenance Measures

Warning!

- ① . Before cleaning the air-conditioning unit, the unit must be stopped and the main power supply of the unit must be shut off.
- ② . Do not wet the air-conditioning unit otherwise there will be danger of electric shock. Never use water to wash the air-conditioning unit.

Precaution!

- ① . Volatile liquid such as thinner or gasoline may damage the finish of air-conditioning unit (only use soft dry cloth or cloth wetted with neutral cleanser to clean the housing of the air-conditioning unit).
- ② . Never use hot water above 45°C to clean the housing of the air-conditioning unit otherwise the unit may lose color or deform.
- ③ . New dry the air filter of the indoor unit above fire otherwise the filter may burst into flame or deform.

9.1 Inspection at the Beginning of Operational Season

- ◆ Check the air inlet and outlet of the indoor and outdoor units to confirm there is no blockage.
- ◆ Check the grounding wire to confirm the grounding is reliable.
- ◆ Check the batteries of the remote controller to see if they shall be replaced.
- ◆ Check the outdoor unit to see if the installation of it is steady. Contact the service center designated by DELTA if there is any abnormal condition.
- ◆ If the air-conditioning unit shall operate again after a long-term shutoff, set the status of the main power supply switch as “ON” eight hours before the start of operation so as to ensure the smooth startup of the air-conditioning unit.

9.2 Maintenance at the End of the Operational Season

- ◆ Clean the filter and the housing of the outdoor unit.
- ◆ Shut off the main power supply of the air-conditioning unit.
- ◆ Remove the dust and foreign articles from the outdoor unit.

9.3 Maintenance Measures

Trouble	Cause	Remedial Measures
Unit does not run at all	Fuse has blown or breaker is OFF	Replace the damaged fuse or close the breaker
	Power cut	Restart the unit after power supply resumes and the unit shall operate
	Power supply is not connected	Connect to power supply
	Batteries of remote controller are weak	Replace with new batteries
	The control distance is too far for the remote controller	The distance shall be within 8m
Unit operates for a while and then stops immediately	Air inlet or air outlet of indoor unit or outdoor unit is blocked	Remove the obstacles
Abnormal cooling or heating	Air inlet or air outlet of indoor unit or outdoor unit is blocked	Remove the obstacles
	Temperature setting is improper	Adjust the setting of remote controller or wire controller
	Air speed is set too low	Adjust the setting of remote controller or wire controller
	Air supply direction is wrong	Adjust the setting of remote controller or wire controller
	Door or window is open	Close door or window
	Under direct sunshine	Hang curtain or blinders before the window
	Too many people inside the room	
	Too many heat sources indoors	Reduce heat sources
	Filter is dirt or blocked.	Clean the filter

For the maintenance measures of different types of indoor units, refer to the operating instructions supplied together with the indoor units.

10. Trouble shooting

10.1 If there is a error detected during operation:

▲ Error code will displayed on the wired controller

Defination of error codes are as blow:

Error code	Error definition
E1	High Pressure protection
E2	Indoor anti-freeze protection
E3	Compressor low pressure protection
E4	Compressor exhaust temp. protection
E5	Compressor Overload or drive error
E6	communication error
E7	Mode conflicts
E9	drain pump flooded protection
F0	indoor temp. sensor error
F1	indoor coil inlet temp. sensor error
F2	indoor coil middle temp. sensor error
F3	indoor coil outlet temp. sensor error
F4	outdoor temp. sensor error
F5	inverter abnormal check error
F6	low voltage error
F7	outdoor defrost temp. sensor error
F9	exhaust temp. sensor error
Fa	overload error
Fb	inverter main board error
Fc	High pressure sensor error
Fd	low pressure sensor error

If error code displaying on the wired controller, please turn off the unit, and request for professional personnel for the troubleshooting.

If there is a error detected during operation:

The error indicator lights on the main board of outdoor units will display.

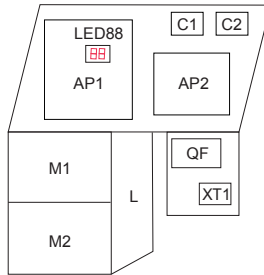

Notes: refer to the actual units for the exact position of the electrical components.

Error types	Display on outdoor LED	Display of wired controller of indoor units
DC busbar over-voltage protection	PH	E5
IPM or PFC over-temperature protection	P8	E5
Current sense circuit error	Pc	E5
IPM or PFC temperature sensor error	P7	E5
Compressor current protection	P5	E5
DC busbar under-voltage protection	PL	E5
Compressor startup failure	Lc	E5
PFC protection	Hc	E5
Drive module reset	P0	E5
Compressor motor desynchronizing	H7	E5
Phase loss	Ld	E5
Drive-to-main-control communication error	P6	E5
IPM protection	H5	E5
High-pressure protection of compressor	E1	E1
Low-pressure protection of compressor	E3	E3
Exhaust temp protection of compressor	E4	E4
Compressor overload protection	H3	E5
Communication error between indoor unit and master controller	E6	E6
Outdoor ambient temp sensor error	F4	F4
Error of temp sensor of outdoor coil inlet	F5	F5
Defrosting temp sensor error	F6	F6

Error of temp sensor of outdoor coil outlet	F7	F7
Exhaust temp sensor error	F9	F9
AC current protection (input side)	PA	E5
Input AC voltage abnormality	PP	E5
Malfunction of jumper	C5	No display
Charging circuit error	PU	E5
High-pressure sensor error	Fc	Fc

10.2 Aftersales Service

In case the air-conditioning unit has any quality problem or you have any inquiry, please contact the local aftersales service agency designated by DELTA.

11. Unit Working Condition

11.1 Rated working condition

	Indoor side state		Outdoor side state	
	Dry bulb temp. °C	Wet bulb temp. °C	Dry bulb temp. °C	Wet bulb temp. °C
Rated cooling	27	19	35	24
Rated heating	20	15	7	6

Note:

- ① . The following listed cooling /heating capacity and noise is tested before outgoing;
- ② . The parameters below are tested under rated working condition. If there is any change to them, please refer to the nameplate;
- ③ . The parameters of heating capacity of indoor unit for heat pump excluded that of auxiliary electric heating power.
- ④ . The performance parameters below are tested according to standard GB/T18837—2002

11.2 The range of production working temperature

Cooling working range	Outdoor temperature 10°C~48°C
Heating working range	Outdoor temperature -20°C~27°C

Thank you for Choosing



www.delta-dct.com

